

# TUFLOC

## INSTALLATION INSTRUCTIONS

### Dodge Charger TufBox

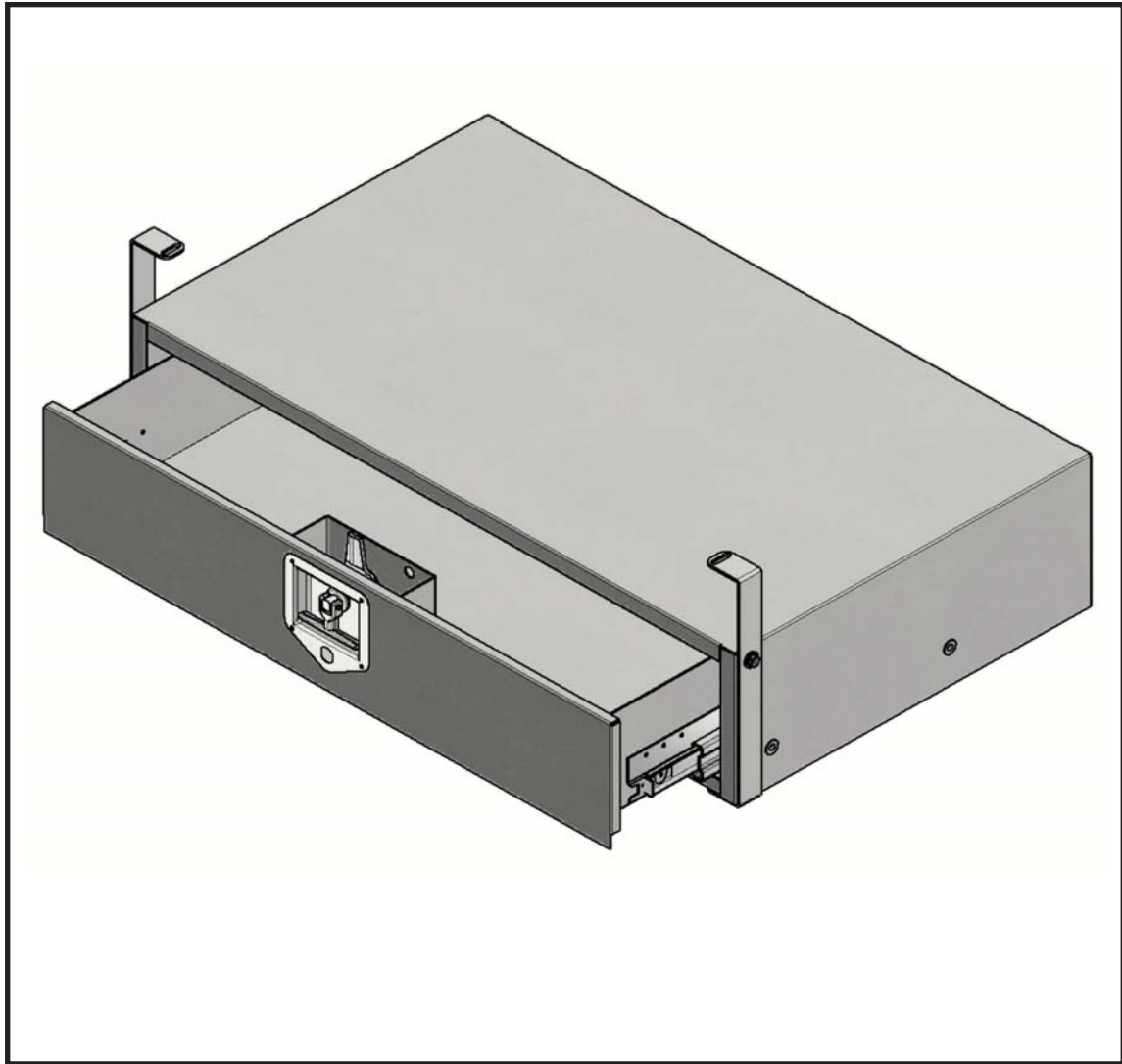

---

### Warranty

Thank you for purchasing the TufBox manufactured by TUFLOC. We have worked hard to develop the best storage box on the market and warrant this product for one year from date of purchase against defects in materials and workmanship. This warranty is limited to replacement or repair of the product only. No other warranties are expressed or implied. Please contact the factory for warranty claims before returning any product.

## Installation

1. Remove the drawer from the cabinet by removing the Slide Securing Screws located on each side of the drawer. Next, while pressing in on the Retaining Tabs located on the sides of the drawer, lift up on the front of the drawer, removing it from the tabs and pull it away from the cabinet. (See Detail A below)

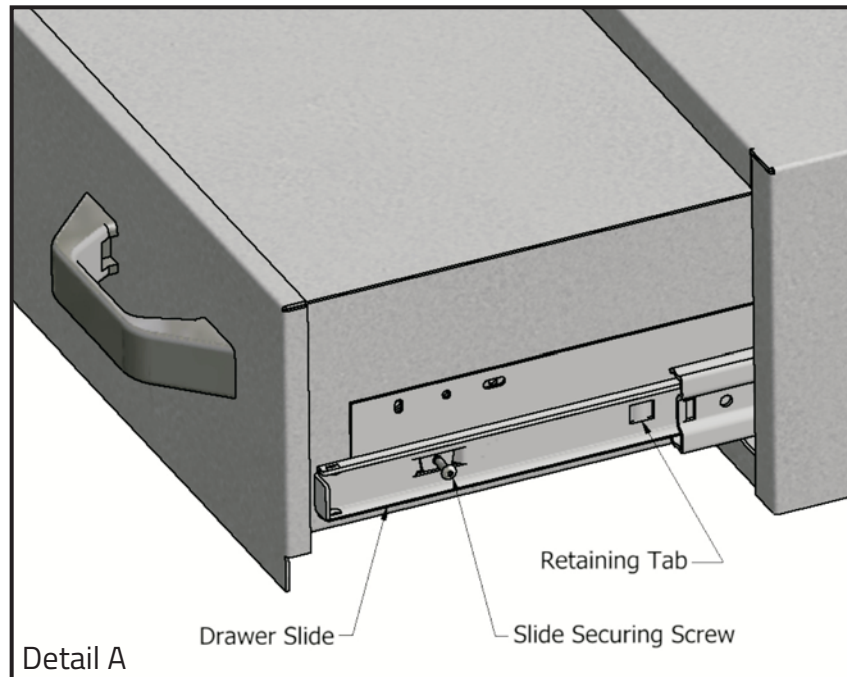

2. Remove spare tire and spare tire bracket. (A full size spare tire will not work with the TufBox. A donut size tire will work but may be difficult getting in and out of trunk).
3. Remove the existing christmas tree fasteners from rear dashboard. It is critical that a  $25/64$ " drill bit is used. Drill through the holes where the christmas tree fasteners were removed being careful to drill through one metal surface only. Once the holes are drilled, place the  $1/4$ " Bolt Inserts as shown below. (See installation next page)

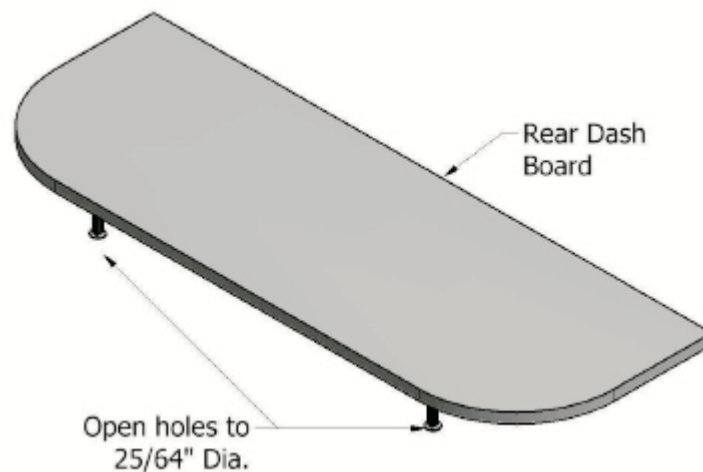

#### 4. Preparing the Rear Dashboard

When fastening the Bolt Insert to the rear dashboard, it is critical that it is completely tightened to ensure the Bolt Insert fully expands. 75 ft-lbs of torque should be used.

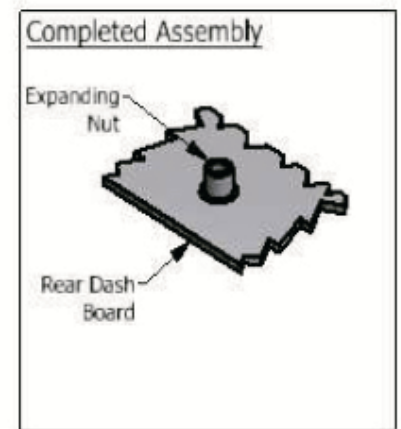
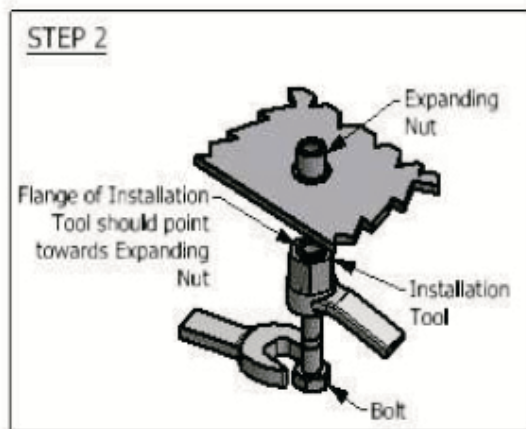
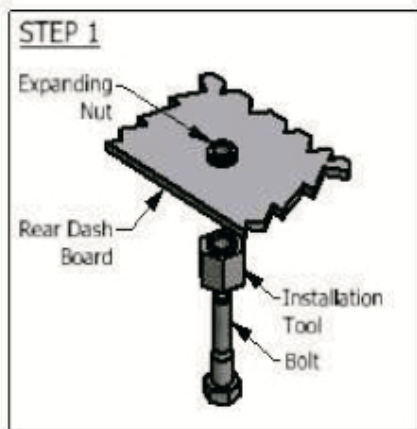
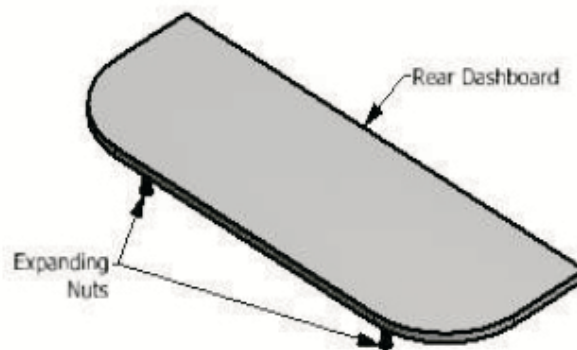
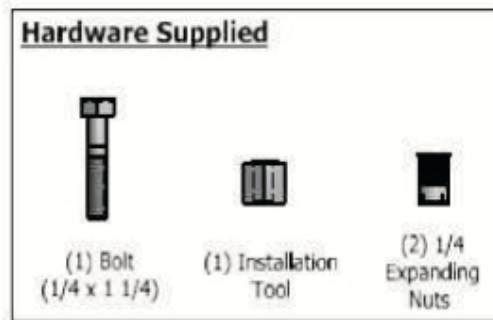

5. Mount front right and left side brace supports using a 1/4-20 x 5/8" flanged hex bolt and fender washers. Do not tighten these bolts completely (See Diagram below)

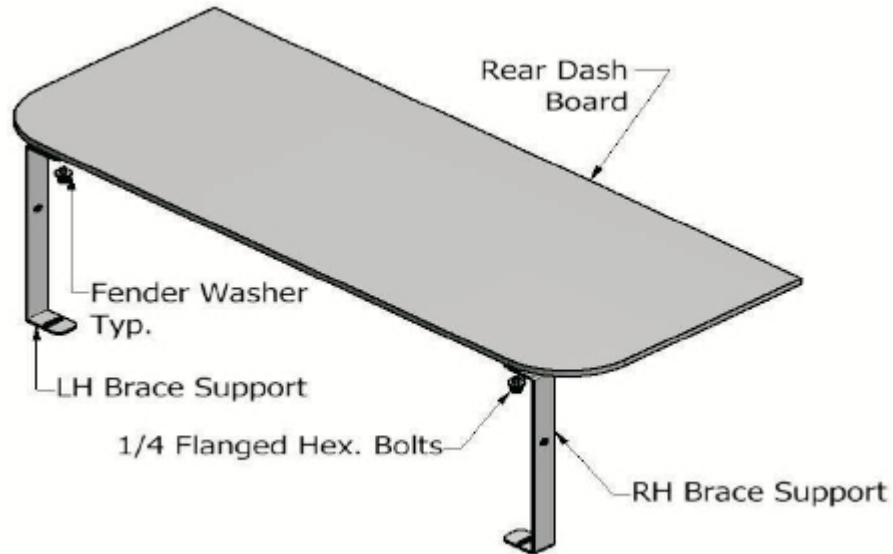

6. Mount the back support brace to the back of the drawer. Note: If the vehicle is a commercial vehicle a rectangular cutout is required for the base of the back support to mount to the floor of the trunk area. The size of the rectangle cutout should be 4" wide x 4" deep and centered at the very back of the removable trunk mat. (See diagram below. The drawer has been omitted for clarity).

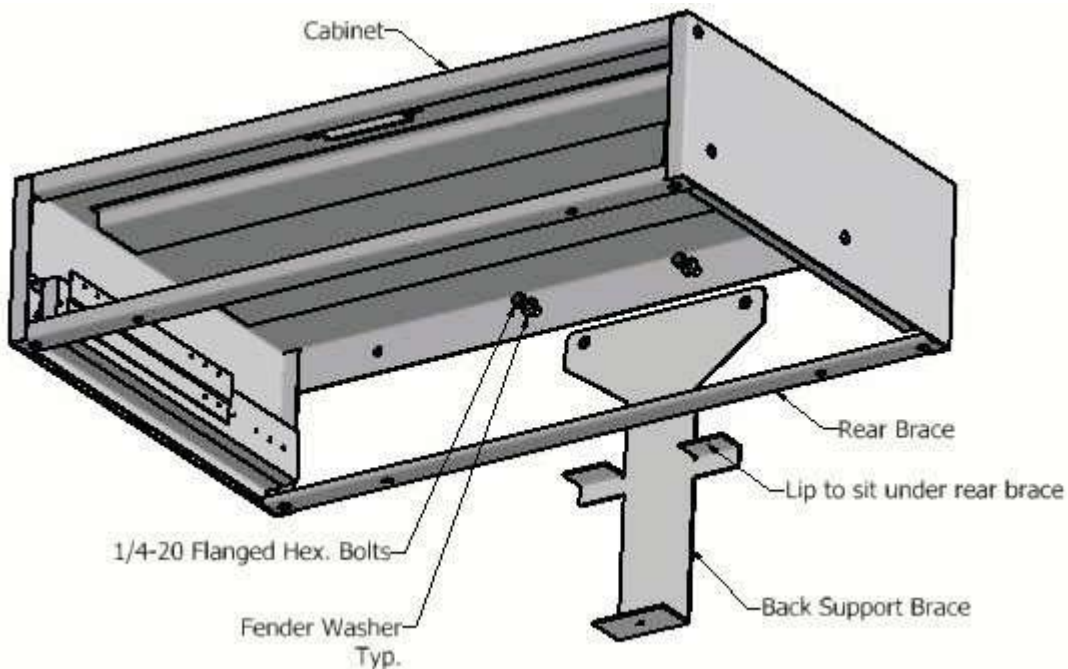

7. Place cabinet into trunk compartment and slide all the way to the rear of the trunk compartment. When done correctly the cabinet front will align with the mounted brace supports (See Diagram Below)

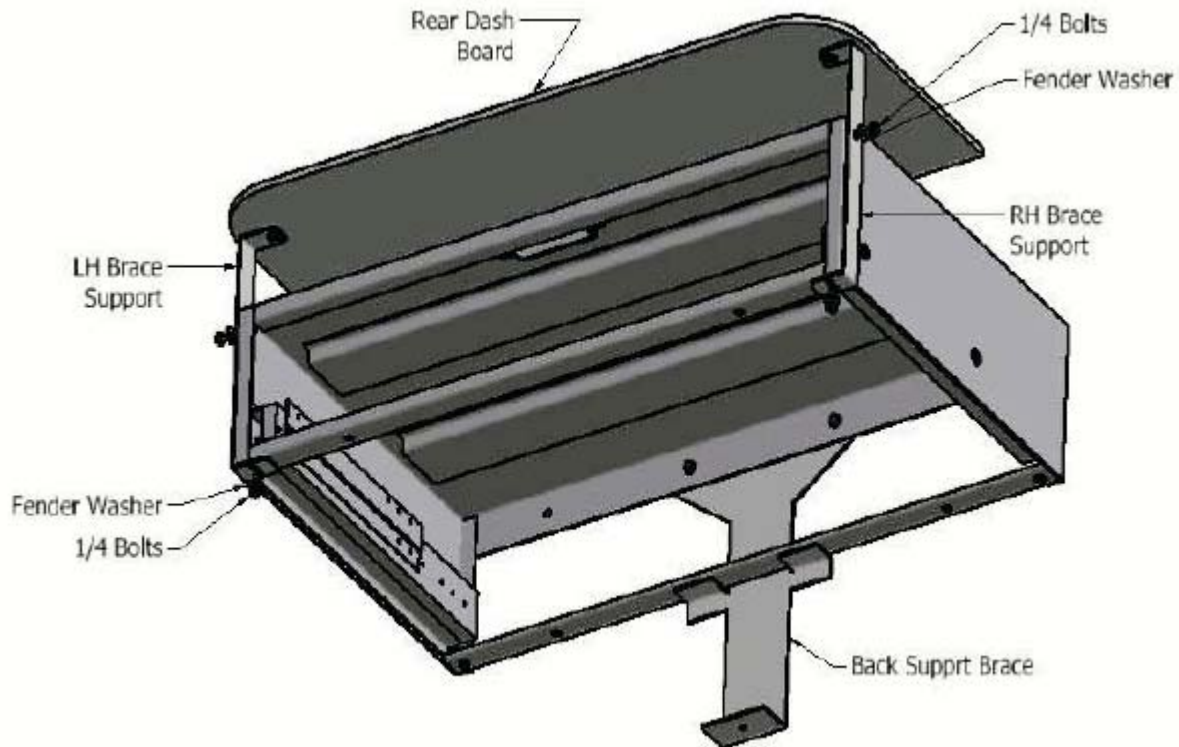

8. Place bolts thru the brace support brackets and tighten completely. Tighten brace support brackets that mount to the rear dash. (See Diagram above)

## Place Drawer into the Cabinet

Place the drawer back into the cabinet by extending the drawer slides and snapping the rails on the Retaining Tabs. You may need an assistant to help align the tabs over the drawer slides. Install the Slide Securing Screws on each side of the Drawer. (See Detail A on Page 2)

## Make Sure the Drawer Functions Properly

Open & close the cabinet drawer to make the sure the drawer is firmly attached to the slides. If the drawer is not firmly attached, remove the drawer, bend the silver tabs outward and replace the drawer.

## Maintenance

- These drawers are intended to hold a maximum weight of 200 lbs. Do not exceed the drawer weight limit. Exceeding the weight limit can make the drawer difficult to operate and can shorten the life of the bearings in the drawer slides.
- The TufBox is designed to provide years of reliable service with minimal maintenance. Occasionally, coat the key with a light petroleum-based lubricant such as WD-40 and insert the key into the lock & turn a few times to lubricate the lock cylinder. NEVER use a graphite based oil. The drawer slides should also be lubricated periodically to assure longer life.
- Standard T-Handle: An adjustable cam can be adjusted to keep the drawer tight and eliminate rattle. (See diagrams below)
- Premium T-Handle: An adjustable roller can be adjusted to keep the drawer tight and eliminate rattle. (See diagrams at left). The Premium T-Handle has the ability for additional security to have a padlock added to the handle (Supplied by others).
- Combination Lock: Please refer to enclosed instruction booklet.

